



특징 (Character)

- 크로스 롤러를 사용한 고정밀 평행 개폐방식
Cross roller guide type
- 롤러 가이드의 병렬배치로 내구성 및 동작안정성 증가
Increase durability and movement stability through roller guide parallel layout
- 개폐 검출용 마그네틱 센서 부착가능
Magnetic sensor is available for open-close sensing
- 소형 경량제품에 적합
Suitable to grip a small and light workpiece
- 비틀림에 강한 플런저
It is strong plunger from twisted
- 높은 반복 정밀도
High repeatability



크로스 롤러 가이드 방식 (Cross roller guide type)

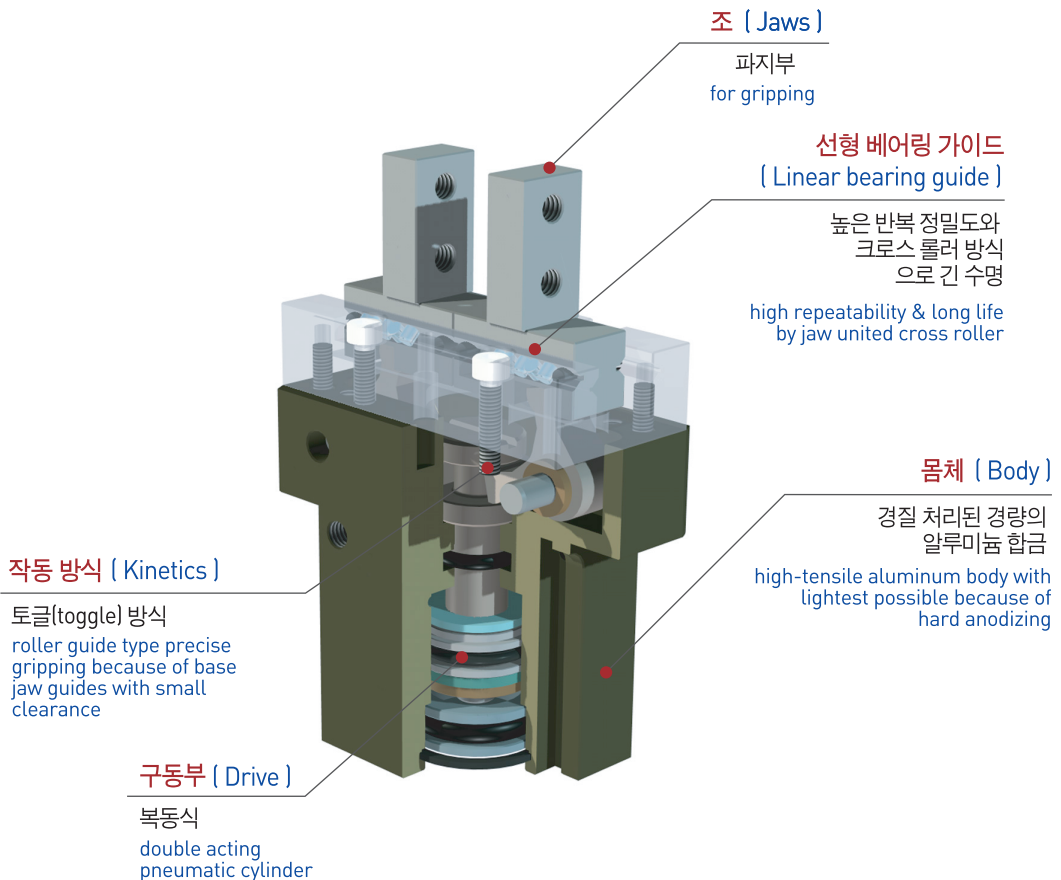

부품분해도 (Exploded view)

※ 본 분해도는 한 제품을 예시하였으므로 기종별로 차이가 있을 수 있습니다
 ※ This exploded view illustrates a certain product only. The contents may vary by product models.

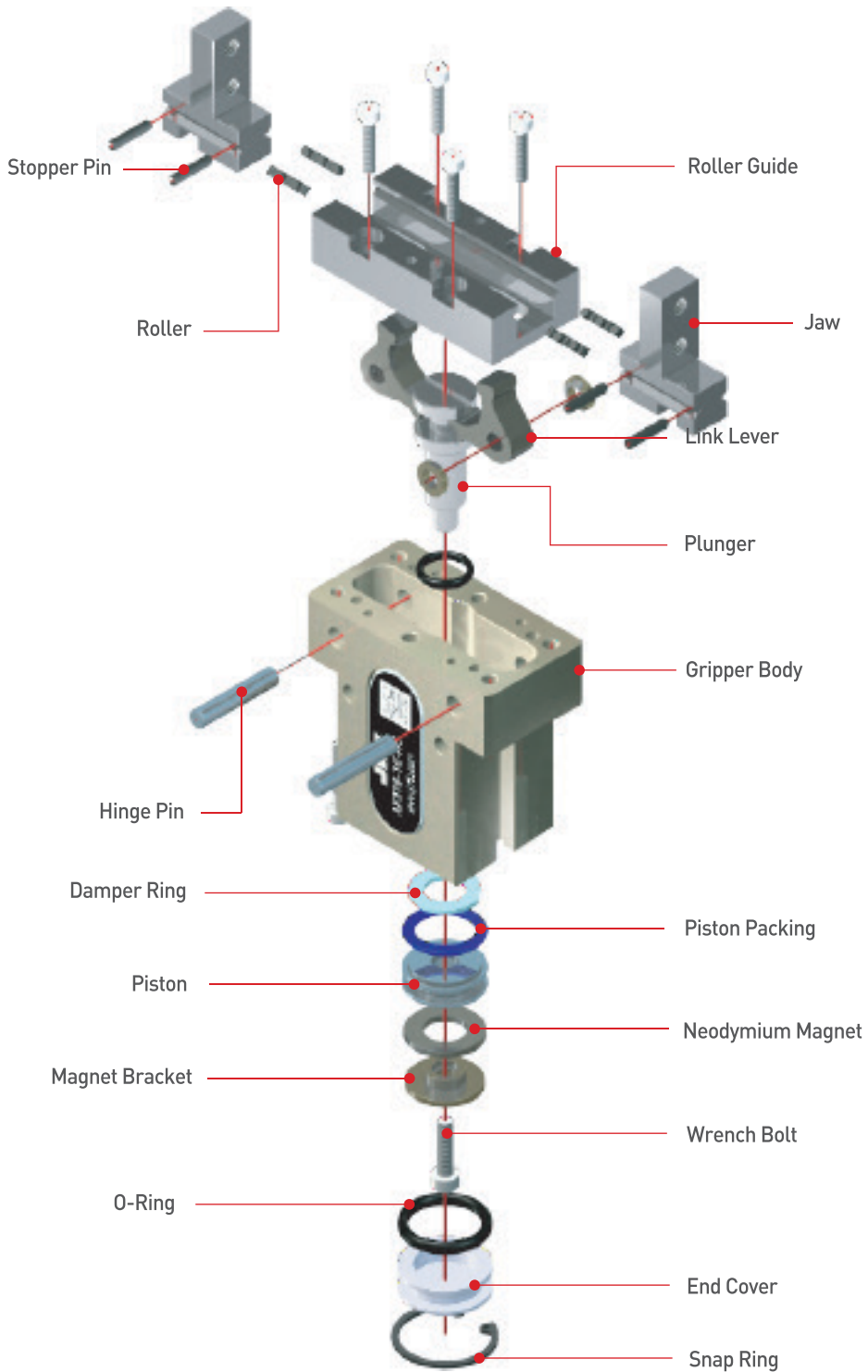

AF101
AF02
AF03
AF04P
AF105P
AF06
AF10
AF13
AF13C
AF14
AF15
AF316
AF17
AF117
AF19
AF24
AF26
AF28D
AF30
AF30L
AF30SP
AF40
AF46
AF56N
RAF56N
MF16

주문기호 (Ordering Code)

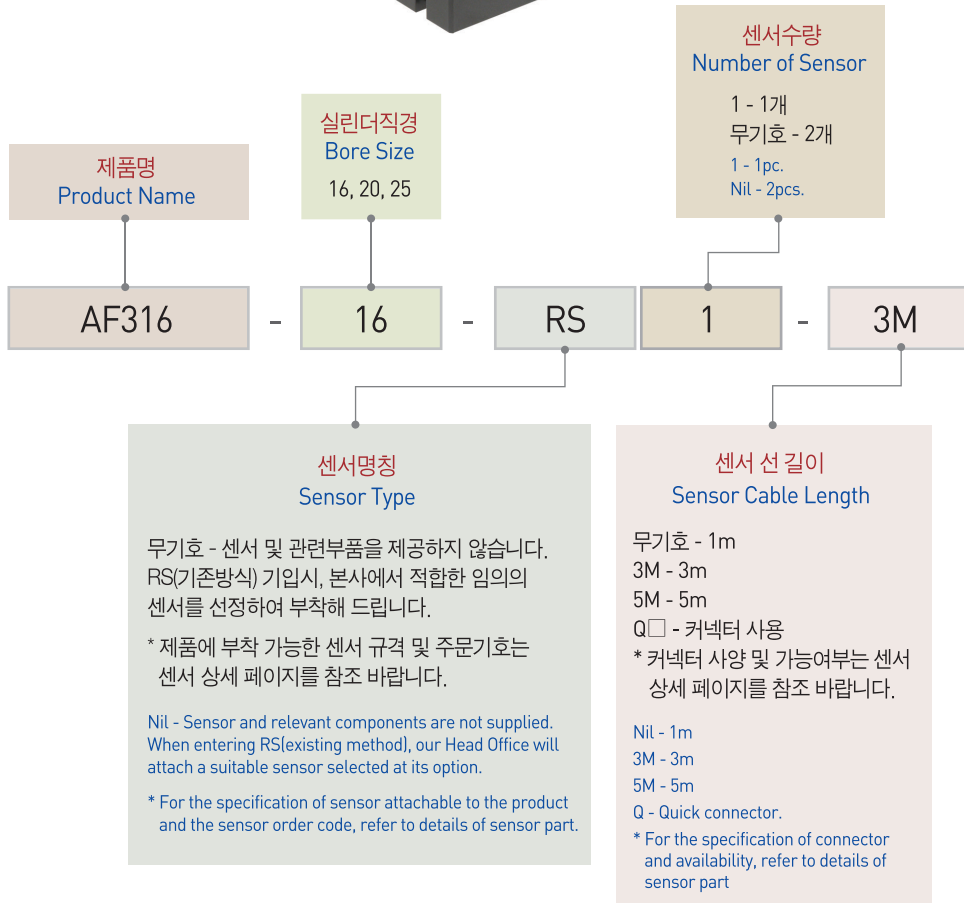

AF316L 주문기호 (AF316L Ordering Code)

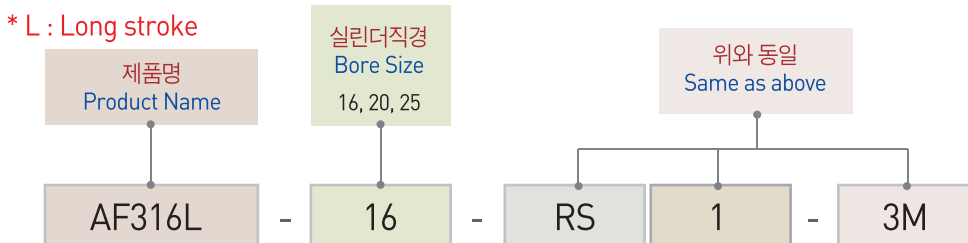

☐ 제품사양 (Specification)

P=공기압력(bar) , L=작업점까지의 거리(mm)
P=Air Pressure(bar) , L=Exertion length(mm)

제품명칭 Products Name	AF316-16		AF316-20		AF316-25		단위 Unit
	Standard	AF316L-16	Standard	AF316L-20	Standard	AF316L-25	
개폐범위 Stroke	8	12	10	18	14	22	mm
제품중량 Weight	0.21	0.26	0.31	0.42	0.55	0.75	kg
최대치구길이 Max. length attach	50		65		80		mm
배관접속구 Fitting size	M5		M5		M5		
파지력 : 열림시 Gripping force : Open	15.3P/(1+0.0075L)		28.35P/(1+0.005L)		42.28P/(1+0.003L)		N
파지력 : 닫힘시 Gripping force : Close	9.52P/(1+0.0075L)		27.96P/(1+0.005L)		39.83P/(1+0.003L)		N
1사이클당 공기소모량 Air consumption per cycle	1.4	2.1	2.7	4.9	6.1	9.6	cm ³
닫힘시/열림시 시간 Closing / Opening time	0.01/0.01		0.01/0.01		0.01/0.01		sec
반복정밀도 Repeat accuracy	0.01		0.01		0.01		mm
연속사용회수 Continuation usage amount	60		60		40		cpm
사용압력 Operating pressure			3~7				bar
주위온도 Ambient temperature			-5 to 60				℃
윤활 Lubrication			불필요 Needless				

반복정밀도 : 연속 100회 작동후 측정치
After 100 consecutive strokes to end positions

- AF101
- AF02
- AF03
- AF04P
- AF105P
- AF06
- AF10
- AF13
- AF13C
- AF14
- AF15
- AF316
- AF17
- AF117
- AF19
- AF24
- AF26
- AF28D
- AF30
- AF30L
- AF30SP
- AF40
- AF46
- AF56N
- RAF56N
- MF16

☐ 작용점에서의 파지력 (Gripping Force From a Point of Action)

범례(Legend) : —●— 7[bar] —■— 5[bar] —■— 3[bar]

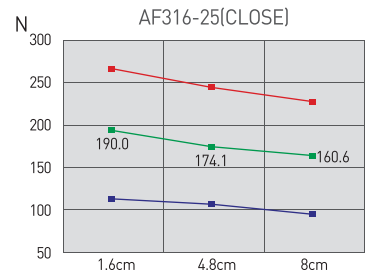
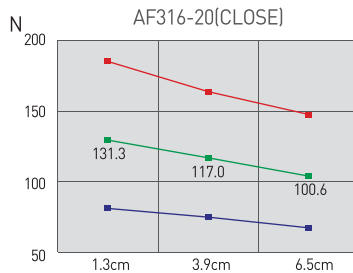
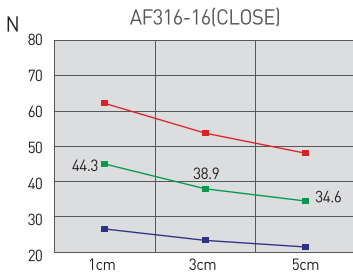
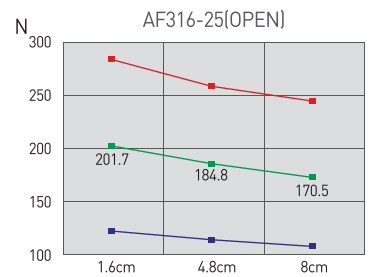
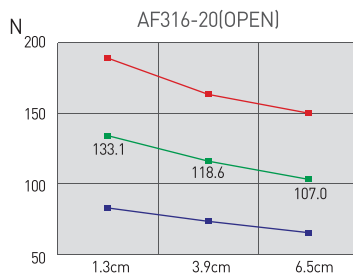
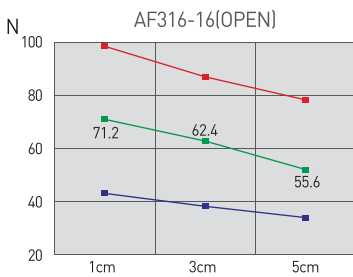

AF316-16

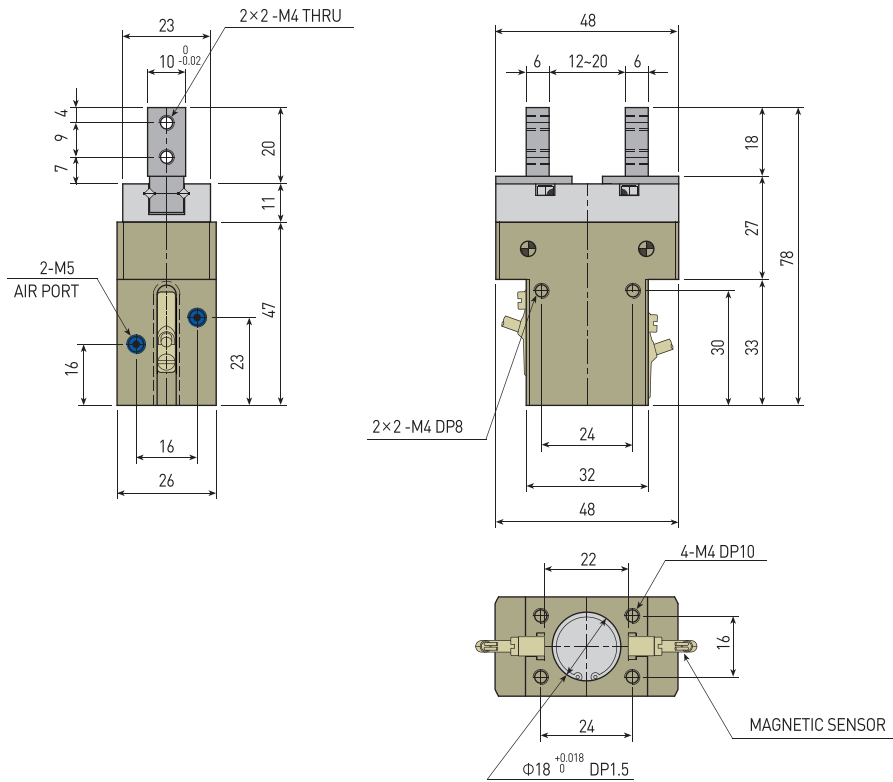

AF316-20

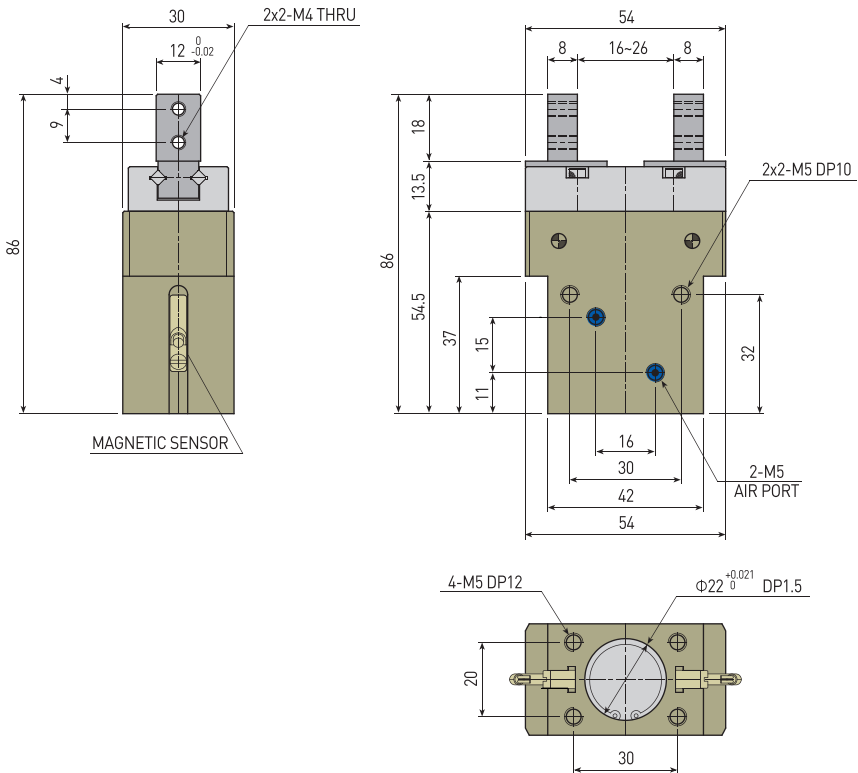

AF316-25

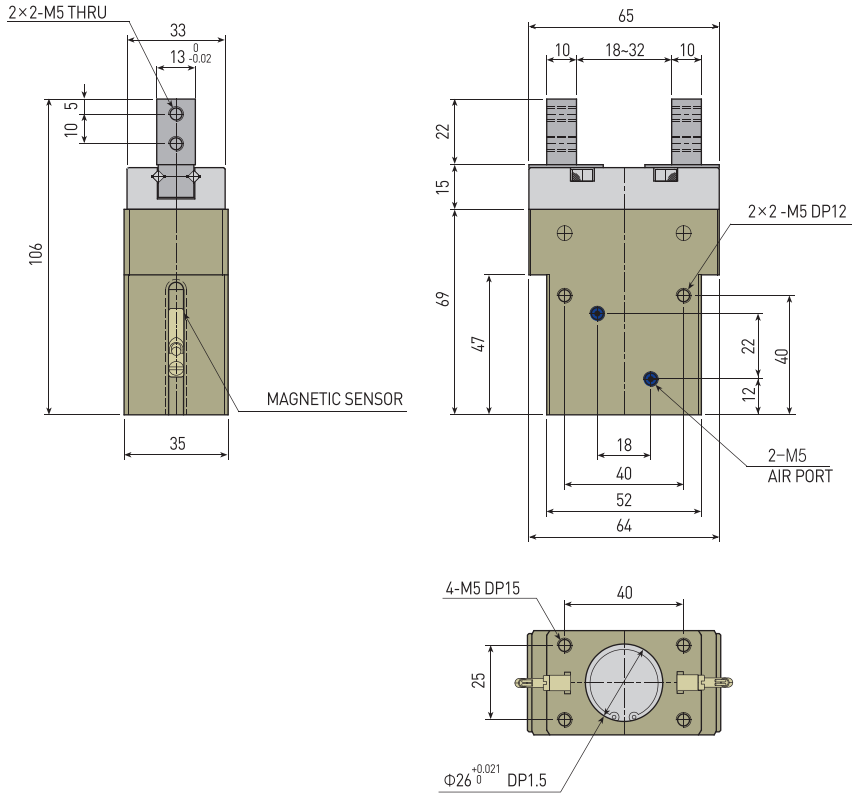

- AF101
- AF02
- AF03
- AF04P
- AF105P
- AF06
- AF10
- AF13
- AF13C
- AF14
- AF15
- AF316**
- AF17
- AF117
- AF19
- AF24
- AF26
- AF28D
- AF30
- AF30L
- AF30SP
- AF40
- AF46
- AF56N
- RAF56N
- MF16

NOTE

Empty box for notes.

AF316L-16

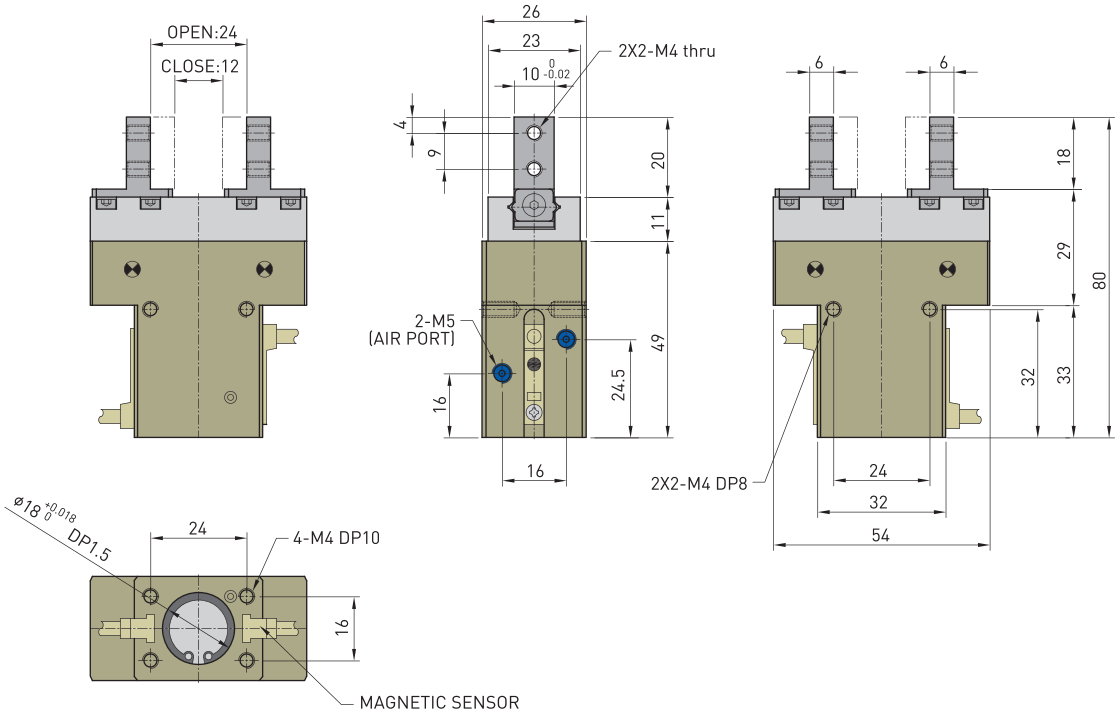

AF316L-20

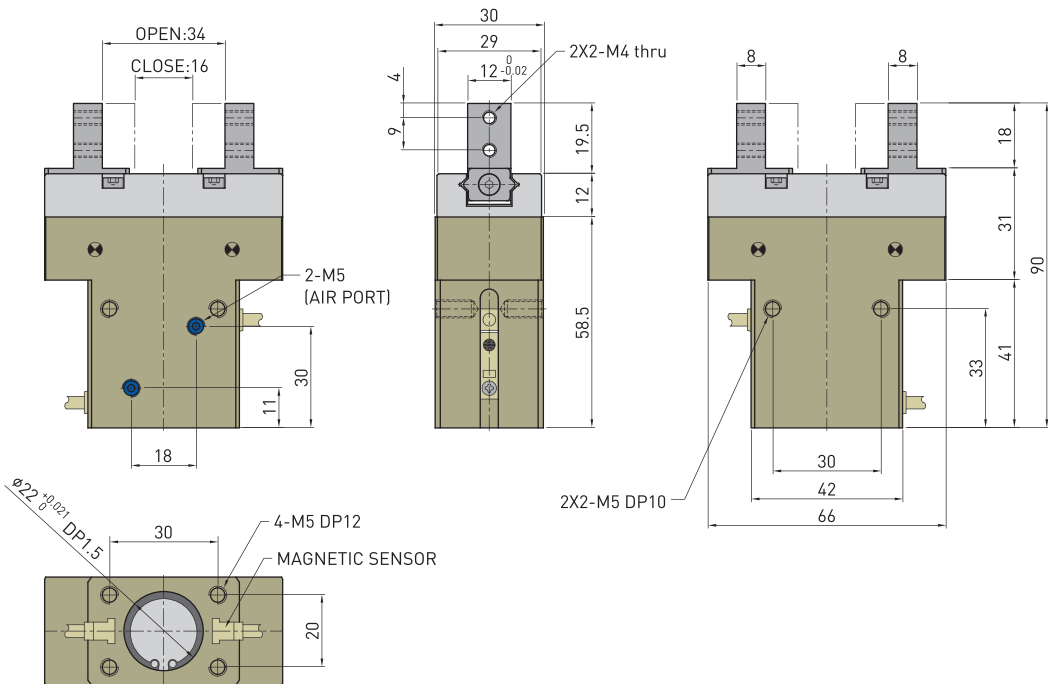

AF316L-25

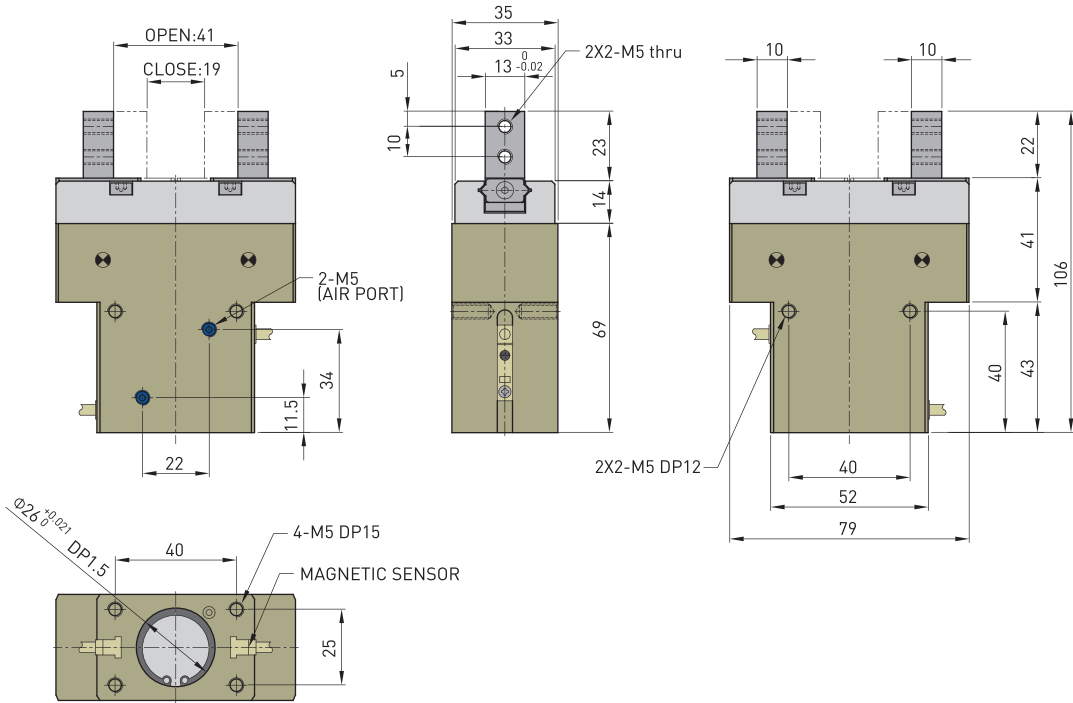

NOTE

- AF101
- AF02
- AF03
- AF04P
- AF105P
- AF06
- AF10
- AF13
- AF13C
- AF14
- AF15
- AF316**
- AF17
- AF117
- AF19
- AF24
- AF26
- AF28D
- AF30
- AF30L
- AF30SP
- AF40
- AF46
- AF56N
- RAF56N
- MF16